



TOTALLY ENCLOSED DIRECT DRIVE

**60030KH, 60031KH, 60050KH, 60051KH 60100KH, 60101KH,
60150KH, 60151KH, 60200KH,60201KH**

MISTING PUMP MANUAL

**INCLUDING: SPECIFICATION DATA, GENERAL SAFETY PRECAUTIONS, OPERATION,
INSTALLATION , PARTS, MAINTENANCE & WARRANTY**

QUALITY MISTING PUMPS

DIRECT DRIVE ENCLOSED MISTING PUMP SPECIFICATIONS

PUMP MODELS	FLOW GPM	MAXIMUM PRESSURE	MOTOR HP	SINGLE PHASE VOLTAGE	MOTOR AMPS	MOTOR RPM	NOISE Db(A)	OIL CAPACITY	.008 NOZZLE CAPACITY	.012 NOZZLE CAPACITY
60030KH	.33	1000	.75	120	8.4	1725	60	8.5 oz.	16	11
60031KH	.33	1000	.75	208-230-1	4.2	1725	60	8.5 oz.	16	11
60050KH	.50	1000	.75	120	8.4	1725	62	8.5 oz.	25	17
60051KH	.50	1000	.75	208-230-1	4.2	1725	62	8.5 oz.	25	17
60100KH	1.0	1000	.75	120	8.4	1725	66	8.5 oz.	50	36
60101KHH	1.0	1000	.75	208-230-1	4.2	1725	66	8.5 oz.	50	36
60150KH	1.5	1000	1.5	120	14.0	1725	70	8.5 oz.	75	54
60151KH	1.5	1000	1.5	208-230-1	7.0	1725	70	8.5 oz.	75	54
60200KH	2.1	1000	1.5	120	15	1725	70	8.5 oz.	100	70
60201KH	2.1	1000	1.5	208-230-1	7.5	1725	70	8.5 oz.	100	70

FEATURES

- CAT PUMP
- TEFC MOTOR
- INLET SOLENOID VALVE
- LIQUID FILLED PRESSURE GAUGE
- WEATHER RESISTANT
- POWDER COAT FINISH
- ON/OFF SWITCH
- CORD CONNECTED

TECHNICAL DATA

MAX. DISCHARGE PRESSURE	1000 PSI
ELECTRIC MOTOR TYPE	TEFC
MOTOR OVERLOAD	AUTOMATIC
FILTER	5 & 1- MICRON
INLET PSI RANGE	FLOODED-60 PSI
MAX LIQUID TEMPERATURE	140° F
WATER INLET VALVE	3/8" SOLENOID
PRESSURE GAUGE	0-2000 psi
SWITCH	Rocker
6 FT. POWER CORD	SJTW-105C
OIL CAPACITY	8.5 oz.

DIMENSIONS

23 1/2" L x 13 1/2" W x 10 3/4" H



WEIGHT

75 lbs.



PUMP OVERVIEW

31041 .75 HP TEFC ELECTRIC MOTOR 120 Volt

31047 .75 HP TEFC ELECTRIC MOTOR 208-230 Volt 1 Phase

31043-1 1.5 HP TEFC ELECTRIC MOTOR 120 Volt

31043 1.5 HP TEFC ELECTRIC MOTOR 208-230 Volt 1-Phase

PRESSURE REGULATOR (CLOCKWISE INCREASES
PRESSURE) **DO NOT EXCEED 1000 PSI**

31000 ROCKER SWITCH



30103 POWER CORD

26038 **WATER INLET HOSE** 3/8" ID sold per ft.

26104 FEMALE GARDEN HOSE ADAPTER.

26042 HOSE SPLICER 3/8" TO EXTEND HOSE

57003 (2) WATER INLET FILTER HOUSING

52623 COMP.NUT W/ SLEEVE

57251 PRESSURE GAUGE

QUALITY MISTING PUMPS



GENERAL SAFETY PRECAUTIONS

⚠ WARNING CAN cause DEATH, SEVERE INJURY or substantial property damage.

⚠ CAUTION CAN cause MINOR INJURY or property damage.

GENERAL SAFETY PRECAUTIONS

Consequently, it is essential to comply with the instructions in this manual as well as local and national rules and safety regulations.

⚠ WARNING **HAZARDOUS VOLTAGE.** Can cause serious injury or death. Disconnect power before servicing pump. Pump must be connected to a properly grounded circuit. Do not operate pump in wet conditions.

⚠ WARNING **MOVING PARTS.** Pump may start automatically. Disconnect power, before servicing. Lockout/Tag out misting pump.

HOT SURFACES. Can cause serious injury. Do not touch. Allow to cool before servicing.

⚠ WARNING **HIGH PRESSURE WATER.** Bypassing, modifying or removing safety/relief regulator valves can cause serious injury or death. Do not bypass, modify or remove safety/relief valves. If a leak should occur shut unit off before attempting to tighten any fittings or tube repairs. Do not change any pressure settings above maximum rating. Maximum pressure is 1000 PSI / 70 Bar

⚠ CAUTION **RISK OF LEAKING or BURSTING.** Use only suitable tubing and fittings acceptable for pressure of not less than the maximum allowable working pressure of the pump. Remove water from lines and filter bowls during winter months to prevent freezing damage to pump or tubing.

⚠ CAUTION **Install pump in a suitable place to prevent property damage in the event a leak should occur.**

⚠ WARNING Electrical installation and service should be performed by a qualified electrician who is familiar with all applicable local, state and federal laws and regulations.

GENERAL. The motor rating, as shown on the motor nameplate, and the power supply must have compatible voltage, phase and hertz characteristics.

WIRE SIZE. The electrical wiring between the power supply and electric motor varies according to motor horsepower and other factors. Install adequately sized power leads to protect against excessive voltage drop during start-up. Refer to the National Electric Code (NEC) for information on selecting the proper wire size and securing electrical connections. If you connect additional electrical equipment to the same circuit, consider the total electrical load when selecting the proper wire size

DO NOT UNDERSIZE WIRING. DO NOT USE EXTENSION CORDS.



OPERATION

The Aero Mist 1000 PSI Pump takes ordinary city water pressure, which is normally about 50-70 PSI, and “boosts” it up to 1000 PSI. The higher water pressure created by the pump enhances mist cooling and heat absorption in two ways. First, it produces a higher flow of water through the nozzle. More water being expelled from the nozzle means more cooling. Second, it creates a smaller finer mist droplet that allows the droplet to evaporate more quickly. Better evaporation means better cooling.

There are many applications for the 1000 PSI Pump. Applications include patio cooling for homes and restaurants, greenhouses, humidification, dust control, odor control and many more.

Caution, Warning and Safety Instructions:

1. **Warning:** Before plugging in the unit for the first time, read the following section carefully. To reduce the risk of electric shock, plug in supplied grounded cord into a properly grounded receptacle. When servicing this unit, unplug power cord before attempting any service or repair.
2. **Outdoor use ONLY!** Not for indoor use.
3. **Install pump in a suitable place to prevent property damage, in the event that a leak should occur.**
4. Turn water off, and disconnect power to the unit when not in use for extended periods of time.
5. Do not place pump in damp or wet environments.
6. Feed system with potable cold water supply only. Do not connect pump to hot water supply.

Do not expose pump to freezing temperatures. When winterizing disconnect pump from power and water supply, and store in a dry safe place. Make sure all water is drained from the system to prevent damage in the event of a freeze.

INSTALLATION

1. Install pump above grade level on a pre-formed concrete pad (16” x 24”). This pump is non-submersible. Locate pump in a location where flooding and roof runoff does not occur to avoid water damage to the electric motor.
2. Verify water feed to pump location is potable cold water supply only.
3. Connect cold water feed to pump inlet and connect nylon tubing to pump outlet. **Important: Install 50 ft. or more of nylon tubing from the pump to the metal line to prevent line noise and vibration.**
4. Remove black shipping cap on the pump crankcase and install the red breather cap provided. Unit is pre-filled with oil and ready to operate. Oil should be half full on the sight glass when unit is off. Do not overfill.
5. Plug pump into a properly grounded receptacle. Do not use extension cords!
6. On new misting systems, flush lines before installing nozzles. The pump will not build pressure until all of the nozzles are installed.
7. Do not exceed 1000 PSI and do NOT run the pump without water.



MAINTENANCE & PARTS

Change oil every 500 hours of operation or once a year. Use approved pump oil (52025)

Proper oil level is half full on the sight gauge when the unit is off. Do not overfill. Oil capacity is 8.5 oz.

Change water filter cartridge annually or as needed. (57011) 5 micron & 57006 1 micron cartridge.

Winter shutdown:

Unplug pump power cord, shut off water supply, remove filter bowl and drain water. Drain water out of all lines using compressed air to prevent freeze damage.

57011 (5 MICRON FILTER CARTRIDGE)

57006 (1 MICRON FILTER CARTRIDGE)



57251 PRESSURE GAUGE
0-2000 PSI 1/8" MNPT



31000 ROCKER SWITCH 20 AMP



57025 CAT PUMP OIL 21 oz.



30375 SOLENOID VALVE 3/8"



33053 SEAL KIT



66400K LOW WATER PRESSURE
CUT-OUT SWITCH KIT (**Optional:**
Protects pump from running dry)



47216 OIL SEAL



30215-CAT THERMAL PROTECTOR (**Optional:** Protects pump from overheating from excessive bypass)



33058 VALVE KIT



52000-K Drain Valve Kit
(**Optional:** Installs at low point to nylon tubing)



PUMP PARTS



EXPLODED VIEW

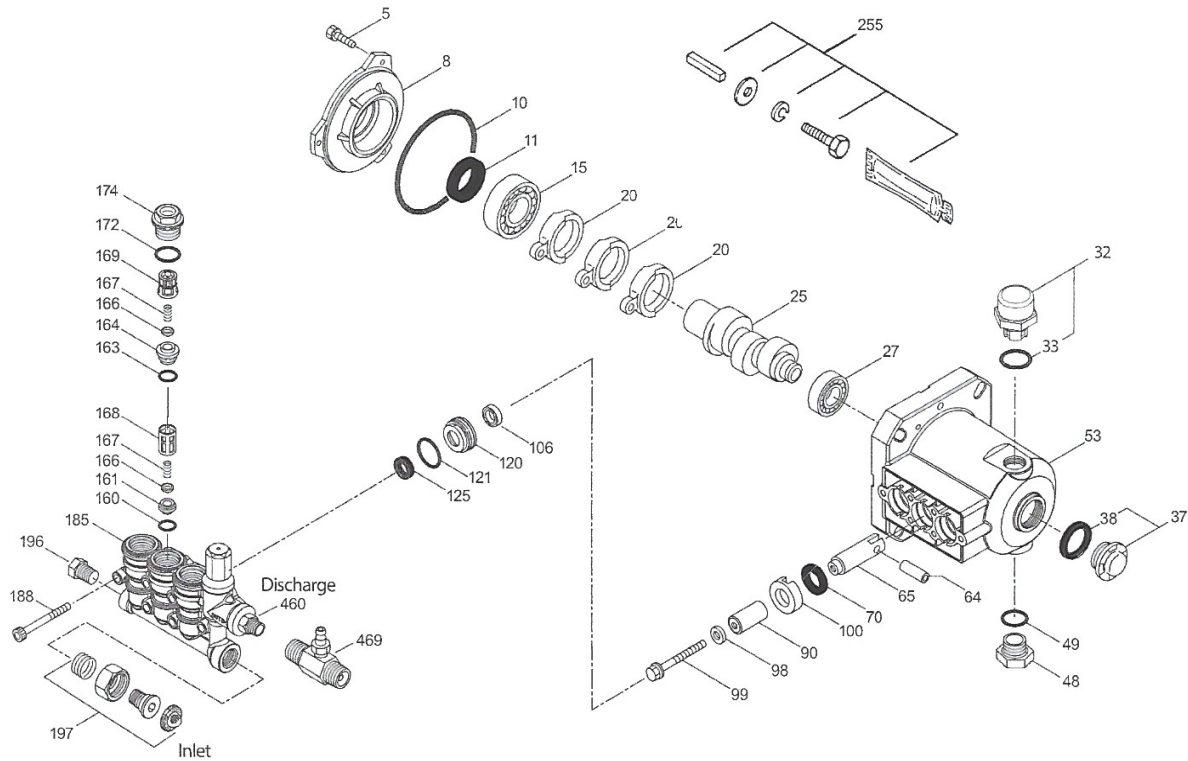

PARTS LIST

ITEM	P/N	MATL	DESCRIPTION	QTY	ITEM	P/N	MATL	DESCRIPTION	QTY
5	549360	STCP R	Screw, HH (M6x14)	3	100	46233	D	Retainer, Seal	3
8	547153	AL	Cover, Bearing	1	106	† 48222	NBR	Seal, LPS w/S-Spg - 85D	3
10	14041	NBR	O-Ring, Bearing Cover - 70D	1	120	547357	BB	Case, Seal	3
11	55337	NBR	Seal, Oil	1	121	13976	NBR	O-Ring, Seal Case - 70D	3
15	14488	STL	Bearing, Ball - Inner	1	125	46240	NBR	Seal, HPS w/S	3
20	547048	TNM	Rod, Connecting	3	160	13965	NBR	O-Ring, Seat, Inlet - 70D	3
25	132183	CM	Crankshaft, 3450 RPM, 5/8", 2.0 mm, 4DX10ER	1	161	545177	S	Seat, Inlet	3
	132185	CM	Crankshaft, 3450 RPM, 5/8", 3.0 mm, 4DX15ER	1	163	19285	NBR	O-Ring, Seat, Discharge - 70D	3
	132186	CM	Crankshaft, 3450 RPM, 5/8", 4.0 mm, 4DX20ER	1	164	545178	S	Seat, Discharge	3
	132187	CM	Crankshaft, 3450 RPM, 5/8", 5.6 mm, 4DX27ER	1	166	46764	S	Valve	6
	132188	CM	Crankshaft, 3450 RPM, 5/8", 6.2 mm, 4DX30ER	1	167	46865	S	Spring	6
27	15710	STL	Bearing, Ball - Outer	1	168	543988	PVDF	Retainer, Spring, Inlet	3
32	549726	—	Cap, Vented w/O-Ring (Rain Cap)	1	169	49764	PVDF	Retainer, Spring, Discharge	3
33	14179	NBR	O-Ring, Oil Filler Cap - 70D	1	172	142807	NBR	O-Ring, Plug - 90D	3
37	92241	—	Gauge, Bubble Oil w/Gasket	1	174	547104	BB	Plug, Valve (M20x1.5)	3
38	44428	NBR	Gasket, Flat Flex, Oil Gauge - 80D	1	185	132192	FBB	Head, Manifold w/Integral Regulator/Unloader Body	1
48	44842	NY	Plug, Drain	1	188	549357	STCP R	Screw, HSH (M6x60)	6
49	14179	NBR	O-Ring, Drain Plug - 70D	1	196	22177	BBCP	Plug, Accessory	1
53	49801	AL	Crankcase	1	197	941516	BB	Assy, GH, 3/8" NPT(F)	1
64	46229	CM	Pin, Crosshead	3	255	30516	STZP R	Assy, Bolt Mount	1
65	132190	BB	Rod, Plunger	3	300	33053	NBR	Kit, Seal (Incls: 98, 106, 121, 125)	1
70	47215	NBR	Seal, Oil - 70D	3	310	76978	NBR	Kit, Valve (Incls: 160, 161, 163, 164, 166, 167, 168, 169, 172)	1
90	542403	CC	Plunger (M16x27)	3	400	—	—	Regulator/Unloader, Integral (See Individual Parts)	1
98	46730	NBR	Washer, Seal - 90D	3	460	107681	BB	Fitting, Discharge	1
99	542405	S	Retainer, Plunger (M6x35)	3	469	7231	BB	Injector, Chemical, Fixed	1

Bold part numbers are unique to a particular pump model. Italics are optional items.

[] Date of latest production change. R Components comply with RoHS Directive. † Production parts are different than repair parts.

See Tech Bulletins 002, 024, 036, 043, 055, 074, 083, 086 and 094 for additional information.

MATERIAL CODES (Not Part of Part Number): AL=Aluminum BB=Brass BBCP=Brass Chrome Plated CC=Ceramic CM=Chrome-moly D=Acetal FBB=Forged Brass NBR=Medium Nitrile (Buna-N) NY=Nylon PVDF=Polyvinylidene Fluoride S=304SS STL=Steel STCP=Steel/Chrome Plated STZP=Steel/Zinc Plated TNM=Special High Strength

NOTE: Discard Key which may come standard with most motors and **use only the key included in this kit.**



Note: Pump is shipped with two black caps w/o-rings for shipping purposes. Remove black cap/w/o-ring from top of pump and install with lug and nut/w/o-ring supplied in box.

WARRANTY

Warranty and Statement

Aero Mist, Inc. warrants to its customers that Aero Mist products, excluding nozzles, to be free of defects in materials and workmanship for a period of (1) year from the date of purchase to the original purchaser. With customers proof of receipt Aero Mist, Inc. will fix or replace the defective part or parts. Aero Mist, Inc. reserves the right to inspect the defective part or parts prior to replacement. Aero Mist, Inc. will not be responsible for consequential or incidental cost or damage caused by the product failure. Aero Mist, Inc., liability under this warranty is limited solely to the replacement or repair of defective parts.

Neither this warrant nor any implied warranty applies to damage or harm caused by any or all of the following:

1. Freight damage
2. Damage cause from freezing, fire, natural disaster, improper installation, chemicals, unusual characteristics of water supply.
3. Damage caused by parts, accessories, or components not obtained from or approved by Aero Mist, Inc.
4. Damage due to misapplication and/or misuse.
5. Normal wear of moving parts or components affected by moving parts
6. Use with flammable materials is forbidden.

The liability of Aero Mist, Inc. under the foregoing warranty is limited to the repair or replacement at the discretion of Aero Mist, Inc. The return of the entire pump or other product to Aero Mist Inc. factory must be within the warranty period, at the sole expense of the purchaser. Upon examination the returned product will be deemed to have been defective in material or workmanship.

AERO MIST, INC., expressly warrants its pumps and other products as above stated. There are no other express warranties. Any implied warranties including implied warranty of merchantability or of fitness for a particular purpose are limited in duration to one year from the date of purchase by the original purchaser except in states that do not allow time limitations on implied warranties. There is no implied warranty of fitness for a particular purpose or merchantability when this product is put to an industrial, commercial or rental use.

No person including any dealer or representative of Aero Mist, Inc. is authorized to make any representation or warranty concerning Aero Mist, Inc. products on behalf of Aero Mist, Inc. or to assume for Aero Mist, Inc. the obligations contained in the warranty. Aero Mist, Inc. reserves the right to install the same upon its existing products or products then in process or manufacture. This warranty gives you specific legal rights, and you may also have other rights, which vary from state to state.

Advanced Misting Systems

216 Avenida Fabricante Suite 207

San Clemente, CA 92672

760-779-1352

www.advancedmistingsystems.com

